

USER INSTRUCTION, SAFETY AND TRAINING GUIDE



NFPA 1971 Compliant Firefighter Helmets

7200 POE AVE.
DAYTON, OHIO 45414
www.LIONprotects.com

July 2024



**PPE Training is
Now Online**

 **Fire Academy™**
www.lionfireacademy.com

Earn your LION NFPA 1500
PPE Safety and Use Certificate

⚠ DANGER

You MUST read this Guide and all Helmet Safety, Cleaning and Information labels before wearing.

Burns are a function of time and temperature. First degree skin burns can occur when skin reaches a temperature of as low as 118° F (47.8° C).

Fire burns at temperatures up to 2000° F (1093.3° C) or higher.

This Helmet provides limited thermal and radiant heat protection in compliance with NFPA 1971. While wearing this Helmet, you may be burned without heat sensation or warning in some circumstances, and without any sign of damage to the Helmet.

Proximity Firefighting Helmet Safety and Cleaning Label

A DANGER

You must read and understand the instructions on this label and contained in the User Instruction, Safety and Training Guide. Failure to comply with these instructions may result in serious injury or death.

- Use only for Proximity Fire Fighting. NEVER contact helmet with molten metals, flames, or hazardous chemical, biological, or radiological agents.
 - Always make sure helmet is properly sized, adjusted and secured.
 - Always wear helmet fully configured with all components in place.
 - Always wear protective hood while wearing this helmet.
 - DO NOT USE AFTER SEVERE IMPACT; RESULTING INTERNAL DAMAGE MAY NOT BE VISIBLE TO USER.
 - Never alter the structure of this helmet, or add flammable components.
 - You must have proper training in proximity fire fighting techniques, and knowledge of the proper selection, fit, use, care and limitation of protective equipment.
 - You must clean your helmet regularly to maintain flame and heat resistance.
- Cleaning Instructions:** Always clean helmet shell, shroud and helmet cover with soap or mild detergent and warm water. Air dry all components. Clean at least 2 times per month. Failure to clean may cause damage to helmet and/or skin irritation.

For information, or for a User Guide, contact LION, 7200 Poe Ave., Dayton, OH 45414 Visit www.LIONprotects.com, or Call 1-800-421-2926

DO NOT MARK ON OR REMOVE THIS LABEL

FI 8998-1036 10/27 5:04

Proximity Firefighting Helmet Certification Label

THIS PROXIMITY FIRE FIGHTING PROTECTIVE HELMET MEETS THE HELMET REQUIREMENTS OF NFPA 1971, 2018 EDITION. FOR COMPLIANCE WITH THE PROXIMITY FIRE FIGHTING OF NFPA 1971, THE FOLLOWING PROTECTIVE ITEMS MUST BE WORN IN CONJUNCTION WITH THIS HELMET:

- GOLD COATED FACESHIELD SHROUD
- ALUMINIZED HELMET COVER
- LFH970G
- LFH1008 or LFH1045
- LFH1011

Read User Guide for list of available part numbers and how properly assembled.

 PROTECTIVE HELMET FOR PROXIMITY FIRE FIGHTING IN ACCORDANCE WITH NFPA 1971-2018

 DO NOT MARK ON OR REMOVE THIS LABEL!

FB 105-0564 11/17

Structural Firefighting Helmet Safety and Cleaning Label

A DANGER

You must read and understand the instructions on this label and contained in the User Instruction, Safety and Training Guide. Failure to comply with these instructions may result in serious injury or death.

- Use only for Structural Fire Fighting. NEVER contact helmet with molten metals, flames, or hazardous chemical, biological, or radiological agents.
 - Always make sure helmet is properly sized, adjusted and secured.
 - Always wear helmet fully configured with all components in place.
 - Always wear protective hood while wearing this helmet.
 - DO NOT USE AFTER SEVERE IMPACT; RESULTING INTERNAL DAMAGE MAY NOT BE VISIBLE TO USER.
 - Never alter the structure of this helmet, or add flammable components.
 - You must have proper training in fire fighting techniques, and knowledge of the proper selection, fit, use, care and limitation of protective equipment.
 - You must clean your helmet regularly to maintain flame and heat resistance.
- Cleaning Instructions:** Always clean with soap or mild detergent and warm water. Air dry all components. Clean at least 2 times per month. Failure to clean may cause damage to helmet and/or skin irritation.

For information, or for a User Guide, contact LION, 7200 Poe Ave., Dayton, OH 45414 [HTTP://www.lionprotects.com](http://www.lionprotects.com), or Call 1-800-421-2926

DO NOT REMOVE OR WRITE ON THIS LABEL

FI 8927-054

Structural Firefighting Helmet Certification Label

THIS STRUCTURAL FIRE FIGHTING PROTECTIVE HELMET MEETS THE STRUCTURAL FIRE FIGHTING HELMET REQUIREMENTS OF NFPA 1971, 2018 EDITION. FOR COMPLIANCE WITH THE STRUCTURAL FIRE FIGHTING HELMET REQUIREMENTS OF NFPA 1971, THE FOLLOWING PROTECTIVE ITEMS MUST BE WORN IN CONJUNCTION WITH THIS HELMET:

- EAR-NECK PROTECTOR
- GOGGLES OR FACESHIELD

Read User Guide for list of available part numbers and how properly assembled.

 PROTECTIVE HELMET FOR STRUCTURAL FIRE FIGHTING IN ACCORDANCE WITH NFPA 1971-2018

 DO NOT MARK ON OR REMOVE THIS LABEL!

FB 105-0564 11/17

TABLE OF CONTENTS

1.	Introduction	3
2.	Definitions	4
3.	Safety Checklist	7
4.	Purpose and Limitations	8
5.	Helmet Construction, Features and Function	10
6.	Inspecting Your Helmet	12
7.	Donning, Doffing, Fit and Adjustment	13
8.	Marking Considerations	16
9.	Using Your Helmet Safely: How to Minimize the Risk of Injury	16
10.	Cleaning, Decontamination and Disinfection	20
11.	Repair Methods/Installation of Replacement Parts	23
12.	Storage	29
13.	Retirement	30
14.	Disposal	30
15.	Limited Warranty Information	31
16.	Inspection, Cleaning, Repair, Retirement and Disposal Record	32

1. INTRODUCTION

Congratulations on purchasing your new LION product. Your NFPA 1971 Compliant Structural Firefighting Helmet or Proximity Firefighting Helmet (referred to throughout this Guide as “NFPA 1971 Compliant Helmet” or “Helmet”) is designed to provide limited protection in firefighting operations. It and its components are manufactured and certified under the performance requirements of NFPA 1971: Standard on Protective Ensembles for Structural Firefighting and Proximity Firefighting. The helmet is either certified in the structural configuration or the proximity configuration (See section 5, page 10 for details).

The User Instruction, Safety and Training Guide gives important instructions regarding the use, inspection, care, maintenance, storage and retirement of your Helmet. No one except you, the trained firefighter, should remove this Guide from your Helmet. Immediately upon receipt of your Helmet, you should remove, carefully read and save this Guide in a three-ring binder for future reference.

Firefighting is an extremely dangerous profession. The circumstances of each hazardous situation are unique and often impossible to predict. This Guide is a training tool to help you understand NFPA 1971 Structural Firefighting and Proximity Firefighting Helmets and how to use it in the safest possible manner during dangerous firefighting operations. Please take the time to read it.

For your personal safety, be alert for important safety messages in this training guide:

 **DANGER**

DANGER Indicates immediate hazards that will result in serious personal injury or death if not avoided, or if instructions, including recommended precautions, are not followed. The signal word “**DANGER**” is highlighted in red, both in this training guide and on labels affixed to your protective Helmet, to indicate the extreme hazard of the situation.

 **WARNING**

WARNING Indicates potentially hazardous situations that could result in serious personal injury or death if not avoided, or if instructions, including recommended precautions, are not followed. The signal word “**WARNING**” is highlighted in black in this training guide.

 **CAUTION**

CAUTION Indicates potentially hazardous situations or unsafe practices that could result in minor or moderate personal injury or product or property damage if instructions, including recommended precautions, are not followed. The signal word “**CAUTION**” is highlighted in gray in this Guide.

2. DEFINITIONS

AFF – Aqueous Film-Forming Foam agents.

A foaming agent capable of forming water-solution films on the surface of flammable hydrocarbon liquids.

ASTM – Acronym for American Society of Testing and Materials

Aramid Fibers – Specially manufactured polymer fibers in which the fiber-forming material consists of linked, long chain-like structures of large molecules. Aramid fibers exhibit higher resistance to flammability, higher strength and higher elasticity than ordinary synthetic or natural fibers. Fabrics made from aramid fibers maintain their integrity at high temperatures and are used in protective clothing and other industrial applications.

Authority Having Jurisdiction (AHJ) – An organization, office or individual responsible for enforcing the requirements of a code or standard, or for approving equipment, materials, an installation or a procedure.

Body Substance Isolation – A concept practiced by emergency response personnel whereby blood and ALL other body fluids are considered a risk for transmission of bloodborne diseases.

Biological Agent – Biological materials that could be capable of causing disease or long-term damage to the human body.

Biological Terrorism Agents – Liquid or particulate agents that can consist of a biologically derived toxin or pathogen to inflict lethal or incapacitating casualties.

Bloodborne Pathogen – Pathogenic microorganisms that are present in human blood and can cause disease in humans. These include, but are not limited to: Hepatitis B, Hepatitis C, HIV and Syphilis.

Body Fluids – Fluids produced by the body including, but not limited to, blood, semen, mucus, feces, urine, vaginal secretions, breast milk, amniotic fluid, cerebrospinal fluid, synovial fluid and pericardial fluid.

Body Fluids-Borne Pathogen – An infectious bacterium or virus carried in human, animal, or clinical body fluids, organs or tissue.

CBRN – An abbreviation for chemicals, biological agents and radiological particulates hazards.

Chemical Terrorism Agents – Liquid, solid, gaseous and vapor chemical warfare agents and toxic industrial chemicals used to inflict lethal or incapacitating casualties, generally on a civilian population, as a result of a terrorist attack.

Component – Any material, part or subassembly used in the construction of the NFPA 1971 Compliant Helmet or element of the NFPA 1971 Compliant Helmet.

Composite – The layer or combination of layers of the protective ensemble, or any elements of the protective ensemble, providing the required limited protection.

Emergency Medical Operations – Delivery of emergency patient care and transportation prior to arrival at a hospital or other health care facility.

Entry Firefighting – EXTRAORDINARILY specialized firefighting operations that can include the activities of rescue, fire suppression, and property conservation at incidents involving fires producing extreme levels of conductive, convective, and radiant heat; such as aircraft fires, bulk flammable gas fires and bulk flammable liquid fires. Highly specialized thermal protection from exposure to extreme levels of conductive, convective and radiant heat is necessary for persons involved in such EXTRAORDINARILY specialized operations and because direct entry into the flames is made. Your NFPA 1971 Compliant Helmets are NEVER to be used for entry firefighting or any direct contact with flames or molten metals, and do not provide the required level of protection.

Exposure Incident – Specific contact of the following with blood or O.P.I.M.: 1) eye; 2) mouth or other mucous membranes; 3) non intact skin; or 4) parenteral contact.

Facecloth – Lining fabric that is used to cover inner surfaces.

Flame Resistance – The property of a material whereby combustion is prevented, terminated, or inhibited following the application of a flaming or non-flaming source of ignition, with or without subsequent removal of the ignition source. Flame resistant can be an inherent property of a material, or it can be imparted by specific treatment.

Flame Retardant – A chemical compound that can be incorporated into materials or a textile fiber during manufacture or treatment to reduce its flammability.

Flash Fire – A fire that rapidly spreads through a diffuse fuel, such as a dust, gas, or the vapors of an ignitable liquid, without the production of damaging pressure.

Fluorescence – The process by which radiant flux of certain wavelengths is absorbed and reradiated, nonthermally in other, usually longer, wavelengths.

Fluorescent Trim – Trim that absorbs and re-radiates light of certain wavelengths, making a surface highly visible to the human eye in order to provide daytime visibility.

Helmet – Also referred to as NFPA 1971 Compliant Helmet.) The term Helmet used throughout this Guide refers ONLY to NFPA 1971 Compliant Firefighter Helmets.

Helmet Shell – The outermost layer of the Helmet with the exception of trim, hardware and eye/face protectors. Also referred to as “shell”.

Guide – Means this User Instruction, Safety and Training Guide.

Heat Flux – The thermal intensity indicated by the amount of power per unit area. The heat flow rate through a surface of unit area perpendicular to the direction of heat flow.

ISP (Independent Service Provider) – An independent third party utilized by an organization (fire department) to perform any one or any combination of advanced inspection, advanced cleaning, or repair services.

Interface Area – An area of the body where the protective garments, helmets, gloves, footwear, or SCBA facepiece meet. i.e., The protective coat--helmet--SCBA facepiece area, the protective coat--protective trouser area, the protective coat--protective glove area, the protective trouser--protective footwear area.

NFPA – Acronym for National Fire Protection Association. A private sector, volunteer-based standard-making organization in the United States that develops guidelines related to fire protection and prevention.

NFPA 1971 Compliant Helmet – Also referred to in this Guide as Helmet). Means a Helmet certified by a private, third party certification organization (for example, Underwriters' Laboratories) to meet at the time of manufacture the design and performance requirements of the NFPA 1971 Standards.

OPIM – Acronym for Other Potentially Infectious Materials. Includes semen, vaginal secretions, cerebrospinal fluid, synovial fluid, pleural fluid, pericardial fluid, amniotic fluid, and peritoneal fluid.

OSHA – Acronym for Occupational Safety and Health Administration. A government-based standard-making body that develops public health and safety standards for the workplace.

Parenteral – Piercing through the skin barrier, such as a needlestick injury, human bite or a cut or scrape.

PASS Device – Acronym for Personal Alert Safety Systems. A device that emits an audible signal to summon aid in the event the firefighter or emergency responder becomes disabled.

PKP or Purple-K – a common name for a dry chemical extinguishing agent based on potassium bicarbonate with a purple dye added.

Protective Element – The parts or items that comprise the protective ensemble. The protective ensemble elements are: coats, trousers, coveralls, helmets, gloves, footwear and interface components.

Protective Ensemble (Structural) – Multiple elements of compliant protective clothing and equipment designed in accordance with the NFPA 1971 Standards that, when worn together, provide protection from some risks, but not all risks, of emergency incident operations. The elements of the protective ensemble are coats, trousers, coveralls, helmets, gloves, footwear and interface components.

Proximity Firefighting – Specialized firefighting operations that can include the activities of rescue, fire suppression and property conservation at incidents involving fires producing very high levels of radiant heat, as well as conductive and convective heat such as aircraft fires, bulk flammable gas fires and bulk flammable liquid fires. Specialized thermal protection from exposure to high levels of radiant heat, as well as thermal protection from conductive and convective heat, is necessary for persons involved in such operations. Your Helmet may only be used in proximity firefighting when it has been fitted with the required Helmet cover, shroud, and faceshield, as it will not provide the required level of protection otherwise.

Proximity firefighting operations might be combined with structural firefighting operations. The Authority Having Jurisdiction must conduct a risk assessment to determine the proper protective elements for incidents where both types of firefighting operations occur, or for proximity firefighters who may be required to provide support for structural firefighting operations.

Retroreflection/Retroflective – The reflection of light in which the reflected rays are preferentially returned in the direction close to the opposite of the direction of the incident rays, with this property being maintained over wide variations of the direction of the incident rays.

Retroreflective Markings – A material that reflects and returns a relatively high proportion of light in a direction close to the direction from which it came.

RPP (Radiant Protective Performance) – A test to determine the ability of an outer shell to withstand a measured amount of radiant heat.

SAFER – Acronym for Southern Area Fire Equipment Research. An established body of fire equipment users with expertise in the research and evaluation of firefighting personal protective equipment.

SCBA – Acronym for Self-Contained Breathing Apparatus.

SDS – Acronym for Safety Data Sheet.

Self-Cleaning Tread – A design that prevents the accumulation of stones and debris in the spaces between the tread.

Sewn Seam – A series of stitches joining two or more separate pieces of material(s) of planar structure, such as textile fabrics.

Spunlace – A nonwoven fabric formed by entangling the fibers about each other in a repeating pattern.

Structural Firefighting – The activities of rescue, fire suppression, and property conservation in buildings, enclosed structures, vehicles, marine vessels, or like properties that are involved in a fire or emergency situation.

TPP – Acronym for Thermal Protective Performance. A test in the NFPA 1971 Standards to determine the ability of a Garment composite to protect against a measured amount of thermal and radiant heat.

Trim – Retroreflective and fluorescent materials attached to the outermost surface of the protective ensemble for visibility enhancement. Retroreflective materials enhance nighttime visibility, and fluorescent materials enhance daytime visibility. “Trim” is also known as “visibility markings”.

Useful Life – Useful life of Helmets or Helmet components can be as little as 3 to 5 years with heavy wear and tear and improper maintenance and/or storage. Useful life can be as long as 7 to 10 years if Helmets have been subject to relatively lower levels of wear and tear and have been consistently maintained in a regular cleaning and maintenance program and stored properly.

In compliance with NFPA 1851, Helmets must be retired no more than 10 years from the date of manufacture.

UV (Light or Radiation) – Acronym for Ultraviolet Light. A type of radiated electromagnetic energy commonly found in the sun’s rays.

Universal Precautions – Under universal precautions, blood and certain body fluids of all patients are considered potentially infectious for human immunodeficiency virus (HIV), hepatitis B virus (HBV), and other bloodborne pathogens.

Verified ISP – An Independent Service Provider that has been verified by a certification organization (such as UL or ITS) to perform moisture barrier repairs and major repairs.

3. SAFETY CHECKLIST

Do not use this NFPA 1971 Compliant Helmet until you have checked “YES” to the following:

1. Have you completed formal training in structural firefighting compliant with the approved standard recognized by the Authority Having Jurisdiction, and on the proper use of firefighting equipment, including Helmets?
 Yes No
2. Have you read and understood all the instructions and warnings throughout this Guide as well as all the safety, cleaning and information labels on the Helmet?
 Yes No
3. Will you regularly inspect the Helmet inside and out for any cracks, damage, color change, dirt, contaminants or embrittlement?
 Yes No
4. Have you studied the limitations of your Helmet as described throughout this Guide?
 Yes No
5. Have you checked to make sure that your Helmet fits you properly? Yes No
6. Have you, your safety officer or another appropriate person made plans to ensure that your Helmet is used, inspected, maintained, stored and retired according to instructions in this Guide? Yes No
7. Do you understand that when your skin reaches a temperature as low as 118° F (47.8° C) you will be burned, and that, in some situations, you may not feel a heat sensation or pain while wearing your Helmet, or receive damage to your Helmet prior to being burned? Yes No
8. Have you read, do you understand and do you agree to assume the risks and responsibilities listed in the Personal Responsibility Code? See **FIG. 1** and back cover of this Guide. Yes No

For Proximity Helmets:

1. Have you completed formal training in proximity firefighting compliant with NFPA 1003 *Standard for Airport Firefighter Professional Qualifications*, or other approved standard recognized by the Authority Having Jurisdiction, and on the proper use of proximity firefighting equipment and NFPA 1971 Compliant Proximity Firefighter Protective Ensemble? Yes No
2. Do you understand the proper installation, use, care, cleaning and retirement of the aluminized components? Yes No
3. Do you understand the inspection process for aluminized components to detect signs of degradation? Yes No

If you answered **NO** to any of the questions, **DO NOT WEAR THIS HELMET** until you have read the appropriate sections in this guide and have been properly trained by qualified instructors.

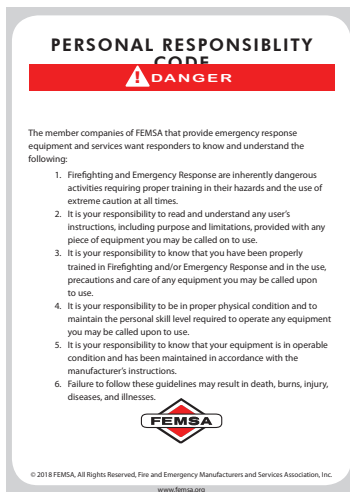

FIG. 1 Personal Responsibility Code. Also shown on back cover of this Guide.

4. PURPOSE AND LIMITATIONS

This protective Helmet is designed to provide LIMITED protection to the head against hazards arising from STRUCTURAL FIREFIGHTING OPERATIONS, AND NON FIRE-RELATED RESCUE OPERATIONS, EMERGENCY MEDICAL OPERATIONS, AND VICTIM EXTRICATION, INCLUDING:

- Heat and flame
- Rain and hose stream water

This Helmet may be used for PROXIMITY FIREFIGHTING OPERATIONS only when it is fitted with an aluminized cover, a gold faceshield and an aluminized shroud. When configured with the appropriate components listed above, THIS PRODUCT SHOULD ONLY BE USED FOR PROXIMITY FIREFIGHTING ACTIVITIES.

DANGER

DO NOT use this Helmet for the following:

- **Entry firefighting operations (see definitions)**
- **Activities requiring direct contact with flames or molten metals**
- **Protection against all hazardous material, chemical, biological, radiological, or nuclear agents or CBRN terrorism agents (see definitions)**
- **Wildland Firefighting**



Do not use for entry firefighting.

DANGER

Fire fighters who are exposed to a flashover, backdraft, or other flame and high heat environments are at **EXTREME** risk for extensive burn injuries and death even while wearing PPE, including a Helmet!



Do not use for direct contact with flames or molten metal.

Emergency response personnel can encounter many common liquids during normal performance of their duties. This helmet and its components do not provide protection from chemicals. The reference to limited protection from liquid splash from 6 common fireground chemicals should not be interpreted to mean that the Helmet is suitable or is permitted to be used for protection to the wearer during any hazardous materials situation.



Do not use for protection against hazardous radiological agents.

WARNING

Controlled laboratory tests in the NFPA 1971 Standard “shall not be deemed as establishing performance levels for all situations to which personnel can be exposed”. You should always use extreme caution in any firefighting situation to avoid the risk of injuries. See NFPA 1971.



Do not use for protection against hazardous biological agents.



Do not use for protection against hazardous chemical agents.

WARNING

Protective properties in a new NFPA 1971 Compliant Helmet will diminish as the product is worn and ages. To reduce the risk of injuries, you **MUST** follow the recommendations in this Guide for inspection and retirement of your Helmet to ensure that the Helmet is not used past its Useful Life.

DANGER

Burns are a function of time and temperature. The higher the temperature of the heat source and the longer the exposure time, the greater the severity of burns.

FIRST DEGREE BURNS

begin when skin temperature reaches approximately **118° F (47.8° C)**.

SECOND DEGREE BURNS

occur when skin temperature reaches approximately **131° F (55° C)**.

THIRD DEGREE BURNS

occur when skin temperature reaches approximately **152° F (66.7° C)**.

You may have **very little or no warning time** from feeling heat or pain before skin begins to burn at 118° F (47.8° C). You need to be constantly aware of the buildup of heat in the surrounding environment and in your Ensemble and be ready to escape to a cool area where you can remove a hot Ensemble quickly to help prevent or reduce the severity of burns.

WARNING

Many fire fighters attempt to push the limits of their protective equipment by performing exercises in burn buildings or training centers for prolonged periods of time. This may result in damage to the Helmet and its components. One frequently sees faceshields melted and turnout gear discolored due to extreme intensity training situations. The Helmet needs to be checked for damage and repaired or retired as appropriate. In these training environments, LION recommends that the firefighter use an aluminized shroud and Helmet cover to protect the Helmet from damage due to continuous exposure to extreme, non-routine fire training conditions.

5. HELMET CONSTRUCTION, FEATURES AND FUNCTION

In order to understand the limits of protection provided by your NFPA 1971 Compliant Helmet, you should study its constructions, features, and function. (FIG. 2, FIG. 3)

Items listed below that are attached to your helmet meet or exceed all performance requirements of NFPA 1971: Faceshields and Goggles and attachment hardware Front/Shield and Front/Shield holders including eagles and hook and loop.

5.1 OVERVIEW

Your NFPA 1971 Helmet provides limited protection to your head from impact, heat, flame, abrasion, cuts and liquids contacted on the fire ground.

5.2 HELMET SHELL ①

The Helmet shell provides the first line of defense against blunt and sharp objects, heat and flame from above, the sides, front and rear. Although strong, the shell is not indestructible. Severe, repeated impacts, exposures to extremely high temperatures, or direct exposure to flame will cause damage to the shell. See inspection process for details.

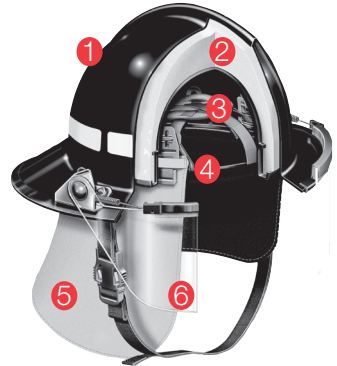

FIG. 2
Key Elements of NFPA 1971
Compliant Helmets.

5.3 IMPACT CAP ②

The impact cap, if your Helmet has one, is constructed of molded expanded polypropylene to attenuate (lessen) harmful energy resulting from impacts, and to insulate the wearer from heat and flame impacting the Helmet shell. Although strong, the impact cap is not indestructible. Severe, repeated impacts, exposures to extremely high temperatures, or direct exposure to flame will cause damage. See inspection process for details.

5.4 SUSPENSION SYSTEM ③

The suspension system attenuates (lessens) the harmful energy during impacts by stretching and slowing the acceleration effect (i.e., like the bumper on a car).

5.5 HEADBAND ④

The headband secures the entire Helmet to the firefighter's head. The firefighter must assure the security of the Helmet by tightening the ratchet band. Severe repeated impacts, exposure to extreme heat or direct flame will cause damage to the headband.

5.6 EAR COVERS ⑤

The ear covers attached to the underside of the Helmet provide very limited protection to the neck, ears and head from heat and flame. The firefighter must assure that the ear covers overlap the upturned and secured turnout coat collar prior to entering a hazardous area.

5.7 FACESHIELD ⑥ OR GOGGLES (not shown)

The faceshield helps protect the eyes, and face from heat, flame and debris. A faceshield is not intended to be used as primary eye protection. Goggles may be used as primary eye protection. A gold faceshield should be used for proximity firefighting operations. Although strong, faceshields and goggles are not indestructible. Severe, repeated impacts, exposures to extremely high temperatures or direct exposure to flame will cause damage.

WARNING

If the situation is hazardous or may become hazardous the use of SCBA and approved facepiece is required. Helmets must include secondary eye and face protection as an installed permanent part of the protective ensemble. Should you decide to eliminate the approved faceshield, an NFPA 1971 compliant mounted goggle must be installed.

5.8 CHINSTRAP 7

Always securely fasten the Helmet to your head with the adjustable chinstrap. Although strong, the chinstrap is not indestructible. Severe, repeated impacts, exposures to extremely high temperatures or direct exposure to flame will cause damage.

5.9 TRIM 8

Retroreflective and fluorescent trim attached to the Helmet shell improves your visibility in low light and daylight conditions. All reflective trim may lose reflectivity under extreme heat conditions.

5.10 LABELS 9

Important safety and cleaning information is located on the labels inside the dome of the Helmet. The Helmet style number, date of manufacture and the name and address of the manufacturer are also located on the labels.



FIG. 3
Additional Key Elements of NFPA 1971 Compliant Helmets.



FIG. 4
Protective Hood

5.11 PROTECTIVE HOOD 10 (sold separately)

The firefighter must wear a protective hood in combination with the ear/neck protector to reduce or eliminate protective gaps around SCBA face piece and the turnout coat collar/Helmet interface.

5.12 PROXIMITY CONFIGURATION COMPONENTS

(Note: Compliant proximity Helmets are labeled and sold with proximity components installed) The following items are required in order to configure Helmets for proximity firefighting. (Part numbers shown below.)

Aluminized Helmet Cover 11 – Provides continuous radiant and thermal heat protection to the Helmet outer shell surface.

Aluminized Helmet Shroud 12 – Provides continuous radiant and thermal protection to the firefighter's head, face (except for the face opening) and neck. Interfaces with the Helmet and with the collar of the aluminized proximity coat.

Gold-coated reflective faceshield 13 – specially coated tinted faceshields with reflective coating to protect the firefighter's face and eyes from exposure to thermal and radiant heat. Gold coated faceshields are extremely dark and filter out a large amount of ambient light in addition to dangerous radiant heat waves.

Canister Cover (not shown) – Available with "J" Models only. This is a specially designed cover for U.S. Air Force (Comes with the J- Fire model Shroud, not shown).



FIG. 5
Helmet Proximity Configuration

Proximity Component Part Guide	Modern Style Helmet	Traditional Style Helmet
Complete Helmets:	Legacy 5 LFH3910G	American Classic LFH2120G
Description	REPLACEMENT PART LOT NUMBER	
Aluminized Helmet Cover	LFH1011	LFH1011
Aluminized Shroud Moisture Barrier with Thermal Liner	LFH1008	LFH1008
Aluminized Shroud for J-Fire Operations with Canister Cover (Military Spec Only)	LFH1045	LFH1045
6" Gold Faceshield	LFH970G	LFH970G

6. INSPECTING YOUR HELMET

Your Helmet should be cleaned, inspected and repaired in a frequency and manner consistent with your fire department's protocol, NFPA 1851 and NFPA 1971.

6.1 PREPARATION

Read all Safety, Cleaning and Information Labels (See Section 5 of this Guide for location). If any of the labels are missing, return the Helmet to the manufacturer immediately.

6.2 FREQUENCY

Routine Inspection:

Inspect your Helmet and components at the following times:

- Upon receipt of your new Helmet or replacement component;
- after each use or at least monthly (whichever is greater) during the useful life of the Helmet;
- after exposure to heat, flames, chemicals or firefighting agents (including AFFF foam and water);
- after exposure to body fluids (including blood); and
- after washing, repair or decontamination.

Advanced Inspection:

Your Helmet should undergo a regular advanced inspection by an expert in the Fire Department who has been trained by LION, LION TotalCare® or a verified ISP at least annually, or whenever you have a question about whether a Helmet is fit for use.

WARNING

Most performance properties of the Helmet and its components cannot be tested by the user in the field.

6.3 INSPECTION PROCESS AND CRITERIA

1. Preparation for Inspection

- A. Wear appropriate gloves during inspection.
- B. Ensure the Helmet is clean. If the Helmet has been contaminated by hazardous materials or biological agents, make sure it has been decontaminated. This is important for your safety, and for assurance that potential problems are not masked by incidental residue.
- C. Place the Helmet on a clean surface in a brightly lighted area.
- D. Separate Helmet components from the Helmet.

2. Inspection of the Helmet

- A. Outer Shell: Examine for dirt, cracks, charring, warping or soft spots. Cracks, charring, warping or soft spots are signs that the outer shell may be damaged or worn out. If your helmet outer shell is compromised, your helmet needs to be retired.
- B. Trim: Check for melting, loss of retroreflectivity and fluorescence, separation from shell.
- C. Impact Cap: Examine for deterioration, cracks or other damage.
- D. Suspension system: Examine for torn or damaged straps or padding.
- E. Faceshield and Goggles: Examine for cracks, scratches, charring, distortions or damage from heat or flame, missing or loose adjustment knobs.
- F. Ear Cover: Look for dirt, tears and signs of light degradation.
- G. Headband: Examine for dirt tears, breaks in the connectors and broken or loose adjustment ratchet.

3. Aluminized Helmet Cover, Shroud and Gold-Coated Faceshield

- A. Aluminized Helmet Cover and Shroud: Examine for dirt, tears, abrasions, delamination of aluminized material. Check thermal liner in aluminized shroud for degradation.
- B. Gold-Coated Faceshield: Examine for scratches, cracks and distortions.

6.4 RECORDKEEPING

LION TotalCare® Centers offer recordkeeping services. For manual records, record all inspections and your results on the Inspection, Cleaning, Repair, Retirement and Disposal Record located in the back of this Guide. Maintain this form unless your organization has provided you with a comparable recordkeeping method for this purpose.

7. DONNING, DOFFING, FIT AND ADJUSTMENT

7.1 PREPARATION

NOTE: Helmet must interface effectively with NFPA certified products which include SCBA (breathing apparatus), coat or garment, hood and ear covers to provide designed limited protection.

You must first put on all protective equipment, including coats, pants, boots, helmet, gloves, hood, SCBA and PASS device before entering any hazard area. **If your department has not purchased faceshields, make sure you are wearing an SCBA unit with a face mask, goggles, or some other form of eye protection, when donning Helmet.**

⚠ WARNING

Always use your chinstrap. Failure to use the chinstrap may result in loss of Helmet during emergency operations.

! CAUTION

Helmet should not interfere with your SCBA or your other protective elements.

7.2. DONNING

Place the Helmet on your head, connect the chinstrap, tighten the headband and engage the faceshield or goggles. If your Helmet is configured for Proximity firefighting, engage the shroud.

7.3 FIT AND ADJUSTMENT

Your safety depends upon the proper fit of your Helmet. You must check the integrity, fit and proper assembly of the Helmet, suspension and chinstrap before each use. Since no two heads are exactly alike, a new Helmet will need to be adjusted to your head's unique size and shape.

A. **Headband Circumference Adjustment:**

1. Turn the ratchet knob counter clockwise until the headband is the largest size. **(FIG. 6)**
2. Place the Helmet on your head and turn the ratchet knob clockwise until the headband is snug but not constricting. One click is approximately 1/8".
3. Connect chinstrap and use buckle to adjust the fit to be snug, yet comfortable beneath the chin.



FIG. 6
Ratcheting Wheel

Additional Headband Circumference Adjustment: (FIG. 7)

If necessary, you can increase or decrease the circumference of the headband beyond the normal range of the ratchet system by altering the point at which the rear ratchet straps connect to the front part of the headband. The factory connects the headband at adjustment point G. To expand or reduce the headband size:

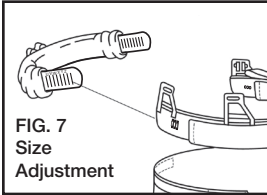

- Remove the Helmet from your head and turn upside down.
- Locate adjustment area identified by three lock tabs on each side of the headband. Letters indicate the position you are selecting to assure equal adjustments on each side. You must adjust each side equally, to assure the ratchet strap stayed centered on the back of the head.
- Slide the strap forward or backward to the desired “lettered” position and snap the strap into place.
- Our headband for American Classic, Heritage and Legacy will accommodate head sizes 5 1/2 to 8 3/4.
- Our headband for Legend X will accommodate head sizes 5 1/2 to 9 1/2.

B. Vertical Adjustment:

Check vertical placement. As a general guideline, the front part of the headband should clear your SCBA mask and the overall settings should have just enough height to clear the tops of the ears. (FIG. 8)

If necessary, you can raise or lower the position of the headband on your head as follows:

1. With helmet off, turn the helmet upside down so internal components are visible.
2. Remove the headband by releasing four retaining tabs from the shell, using recommended LION tool (can be purchased as LION kit #LFH1058). Remove ear covers. (FIG. 9)
3. Set headband brackets to desired position, reinstall earneck and snap the four retaining tabs back into place. (FIG. 10, 11) Note: Front and back can be adjusted differently for more customized fit.
4. Try on for fit. Repeat steps 2 and 3 if additional adjustment is necessary.

For example, if the headband is too low and is too close to your eyes, you should adjust the tabs to position “A”. (FIG. 12) While you can also adjust the front and rear tabs to different heights, please note that the height of the complete Helmet on your head is determined by the suspension straps which have a fixed length.

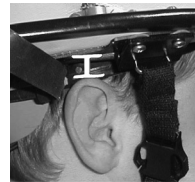

FIG. 8
Helmet Ear Clearance

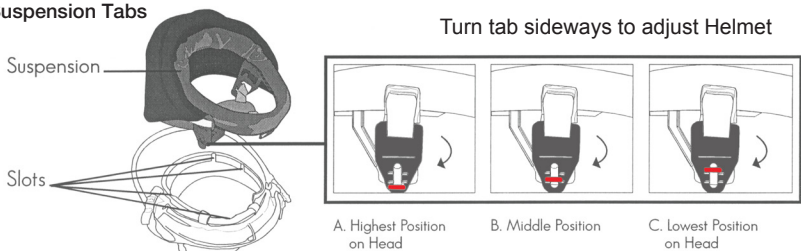

FIG. 9
Headband Detachment



FIG. 10, FIG. 11
Headband Tab Repositioning

FIG. 12
Suspension Tabs



C. **Center of Gravity Adjusting Suspension (FIG. 13)**

The adjustment tab is just in front of the center of gravity pad. Disengage Velcro® and pull the tab to move the center of gravity pad forward. Re-engage Velcro®. By doing this, you move the center point and center of gravity forward also. This will make the Helmet tilt back on your head and move more of the weight to the rear.

FIG. 13
Center of Gravity Adjustment

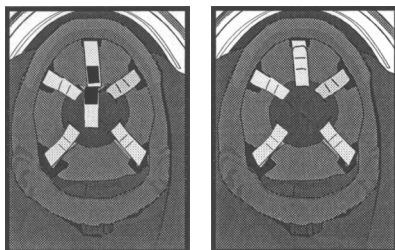

- D. **Fit Check:** To determine whether you have a properly fitting headband, hold your head still and rock the Helmet on your head. A properly fitting Helmet will cause your scalp to move with the Helmet. If necessary, expand or reduce the headband circumference according to the instructions shown in section 7.5 (A).
- E. **Engage Faceshield/Goggles:** If present, lower faceshield into position before entering hazard zone. Make sure the faceshield does not interfere with your SCBA facepiece when fully engaged. If no SCBA faceshield is present, engage the goggles.
- F. **Check Interface Areas for Overlap:** Ask a partner or responsible officer on the scene to make sure that your ear/neck protector overlaps the collar on your turnout coat to provide maximum coverage to the neck area. Always make sure no skin is exposed in interface areas between the Helmet, body, SCBA and collar.

If you have trouble or need special size considerations, contact your nearest authorized LION Helmet™ dealer or call LION at 1-800-421-2926.

7.4 REMOVAL/INSTALLATION OF PROXIMITY COMPONENTS

Compliant proximity Helmets are labeled and shipped with the shroud, cover and gold-coated faceshield installed. To replace damaged or worn components:

- A. **Aluminized Helmet Cover.** To remove old cover, disengage hook-and-loop attachment flap on underside of brim at the faceshield attachment area and pull cover off Helmet. Replace with new cover by first installing cover around front of brim. Pull cover over Helmet and install over rear brim. Engage the side hook-and-loop attachment flaps.

- B. **Aluminized Helmet Shroud.** Attach shroud to Helmet as follows:
1. With helmet off, turn the helmet upside down so internal components are visible.
 2. Reach into the crown of the Helmet below the headband and locate the headband securing tabs.
 3. Remove the headband by releasing four retaining tabs from the shell, using recommended LION tool (can be purchased as LION kit #LFH1058). Remove shroud.
 4. Place new shroud in position so that white fastening tape is facing the outside of the Helmet and is located beneath the first securing tab on the left side of the Helmet. Make sure opening of shroud is facing front of Helmet.
 5. Push retaining tab into attachment slot on locator ring firmly until it snaps into place. Firmly secure fastening tape in the space between the tab and the locator ring.
 6. Continue around the Helmet until all four headband tabs are installed with the shroud tape.
 7. After all four tabs are installed, pull down the shroud to prevent it from bunching in the space between the headband and the locator ring in order to ensure a comfortable fit.
- C. **Gold-coated reflective faceshield.** The gold coated faceshield should be replaced according to the regular procedures for removal and replacement of clear faceshields.

7.5 DOFFING

Never remove your Helmet until you are certain you are safely removed from the hazard area. Always wear your full protective ensemble during all phases of fire suppression, including overhaul activities. Disengage faceshield or goggles. Disconnect the chinstrap and remove the Helmet. Carefully avoid touching any contaminated areas. If your Helmet has the proximity configuration, disengage the shroud first.

8. MARKING CONSIDERATIONS

LION recommends marking only the inside of the rear brim of the Helmet with any permanent marker.

NEVER MARK ON THE HELMET SAFETY OR CLEANING LABELS!

9. USING YOUR HELMET SAFELY: HOW TO MINIMIZE THE RISK OF INJURY

9.1 PREPARATION

Before beginning any emergency operation where there is fire or a threat of fire, make sure that you are wearing your Helmet with full protective clothing, including boots, gloves, turnout gear, hood, SCBA, and PASS device, before entering any hazardous situation. Don your Helmet according to the procedures in Section 7 of this Guide, and have another person check for proper overlap at the interface areas.

DANGER

Always wear a clean and thoroughly dry Helmet in any structural or proximity firefighting operation. A soiled, contaminated or wet Helmet may cause serious burns to the wearer.

WARNING

Always wear engaged SCBA in any hazard area. SCBA provides your primary eye protection in addition to your air supply. Your faceshield is not designed to serve as primary eye protection.

9.2 FIRE CHARACTERISTICS

Fires are inherently dangerous, unpredictable environments.

Temperatures can range upwards to more than 2000° F (1093° C) in a matter of seconds. It is important to understand these conditions in order to maximize your protection and to understand the limited ability of your Helmet to protect you from all hazards that may be present in a fire.

9.3 BURN HAZARDS: TYPES OF HEAT TRANSFER

There are three types of heat transfer in a fire that could cause burns: conduction, convection, and radiation. **Conduction** is the direct transfer of heat through contact with a hot object. **Convection** is the transfer of heat through a medium; for example, air. **Thermal radiation** is the transfer of heat in the form of light energy. Fire fighters experience all three types of heat in a fire, and must understand their effects on an NFPA 1971 Compliant Helmet.

Conduction: In general, **you can be burned** by conductive heat transfer by contacting heated surfaces or objects. Compression brings surfaces closer together and displaces air, resulting in the transfer of heat between outside surfaces and clothing layers. With respect to Helmets, conduction burns are a particular hazard at the neck, face and chin regions. You must be careful to avoid compression of the ear/neck protector, shroud or hood, or contact with hot objects. Also, if Helmets are subjected to repeated or prolonged exposure to high heat, the shells and components can become extremely hot and can cause contact burns.

Convection: Convected heat travels through the air, even if there is no immediate appearance of fire. Convected heat can elevate the temperature of your head and face to a point at which you could be burned.

Thermal Radiation: Thermal Radiation is the transfer of heat in the form of light energy into a material, directly from flames or reflected from hot objects. Factors which affect the speed of radiant heat transfer include: the temperature difference between two surfaces, their distance from each other, and the reflectivity of each surface.

Always use your NFPA 1971 Compliant Helmet properly and in a manner that is consistent with NFPA 1500, Standard on Fire Department Occupational Safety and Health Program and Title 29, Code of Federal Regulations, Part 1910.132, General Requirements of Subpart I, Personal Protective Equipment.



Radiant heat from hot surfaces and flames can cause burns.

 **DANGER**

Convective or Radiant heat can penetrate quickly to your face, head and neck. Dangerous levels of heat may be present inside or outside a structure despite the lack of flames, and burns can occur at relatively low temperatures. If you feel thermal radiation burns developing, cool down your surrounding environment with water or move to another location. Your face, head and neck may be burned without any warning signals.

9.4 BURNS

Burns are a function of time and temperature. The higher the temperature of the heat source and the longer the exposure time, the greater the severity of burns. FIRST DEGREE BURNS begin when the temperature of skin reaches **118° F (47.8° C)**. SECOND DEGREE BURNS occur when the skin reaches approximately **131° F (55° C)**. THIRD DEGREE BURNS occur when skin temperature reaches approximately **152° F (66.7° C)**.

In terms of heat flux, unprotected skin will receive a second-degree burn after only a 30-second exposure at .45 watts per square centimeter. Studies have shown that flame temperatures of low intensity wastebasket fires can reach almost 1300° F (704.4° C), with a heat flux in excess of over four watts per square centimeter, and with air temperatures ranging up to 750° F (398.9° C). Thus, even small fires can generate several times the level of heat to cause severe burns to fire fighters who do not wear ALL their protective ensemble in a secure manner.

 **DANGER**

Damage, discoloration or distortion to a faceshield is an indication of a dangerous environment. To avoid serious injury, you should escape immediately!

 **DANGER**

Prolonged or repeated exposures to heat will increase Helmet temperatures and can cause burns even after the firefighter is no longer exposed to high temperatures. Minimize exposure to heat by using water to cool the environment, or by escaping quickly after a short period of time. Failure to follow these instructions will result in burns.

 **DANGER**

The buildup of heat in your NFPA 1971 Compliant Helmet can lead to burns without any sign of damage to the Helmet. Never wait for signs of damage to warn of imminent burns. Always be aware of your surrounding environment and be ready to escape if you begin to feel tingling or burning sensations.

 **WARNING**

Do not confuse the component testing requirements that are part of NFPA Standards with the conditions in which fire fighters work. For example, the requirement that certain components must not melt, drip, or separate when exposed to convected heat temperatures of 500° F (262° C) for 5 minutes is in no way intended to indicate that fire fighters face that condition in their work, or could be expected to withstand that condition **EVEN WHILE WEARING AN NFPA 1971 COMPLIANT HELMET CORRECTLY** without suffering serious injury or death.

DANGER

Fire Fighters who are exposed to a flashover, backdraft, or other flame and high heat environments are at EXTREME risk for extensive burn injuries and death even while wearing an NFPA 1971 Compliant Firefighter PPE including a Helmet!

DANGER

- You may have very little or no warning time from feeling heat or pain before skin begins to burn at 118° F (47.8° C).
- You need to be constantly aware of the buildup of heat in the surrounding environment and in your Helmet and be ready to escape to a cool area where you can remove a hot Helmet quickly to avoid burns.

9.5 HEAT STRESS: A SIGNIFICANT CAUSE OF FIREFIGHTER INJURIES

Physical work in a warm or hot environment causes a rise in the temperature inside the body. To protect the body against heat, the heart begins to beat faster so that more blood can be moved to the skin surface. Blood vessels near the skin dilate so that they can carry more blood. In this way, blood in the interior of the body can be brought out near the body's surface and cooled. Most importantly, the body produces sweat that evaporates off the skin to provide cooling. Those natural responses do not work very well for any or all of the following conditions: the ambient air temperature is at least 75° F (23.9° C) or higher, the PPE elements' insulation blocks the transfer of heat away from the body, it blocks the evaporation of sweat, or the exertion of the muscles produces more heat than the system can remove. When the body temperature gets elevated too high, the results can be heat strain, heat exhaustion, or heat stroke.

WARNING

Overexertion in hot conditions while wearing NFPA 1971 Compliant PPE, including a Helmet, can lead to heat exhaustion or heat stroke. Symptoms of heat exhaustion are a general feeling of weakness, dizziness, rapid pulse, low blood pressure while standing or sitting and/or a headache. The skin may feel moist or clammy. If you feel symptoms, get to a cool place, remove your Helmet, other PPE and drink fluids. Failure to seek attention could lead to coma or death.

WARNING

Symptoms of heat stroke are hot, dry skin with no sweating, very high body temperatures, weakness, dizziness, rapid breathing, nausea, unconsciousness and sometimes mental confusion. If you feel any of the above symptoms at any time, get to a cool area immediately, remove your Ensemble, drink fluids and seek medical attention. Failure to seek attention could lead to coma or death. Immediate cooling is essential for survival in heat stroke cases.

9.6 HEART ATTACKS: A RESULT OF OVEREXERTION

During firefighting operations, the heart beats faster because of the need to move more blood to the working muscles. This blood carries more oxygen to the muscles so that they can handle the increased workload. Another factor in increasing the rate of the heart is the presence of adrenaline, the "fight or flight" hormone, in the firefighter's body during an emergency. The adrenaline present in your system causes the heart to pump even faster than during normal activity. All of these stress factors could place too much strain on the heart, leading to a heart attack. The heart simply cannot handle the load placed on it.

WARNING

You must be physically fit to safely perform strenuous work under stressful conditions. Regular cardiovascular exercise, abstaining from cigarette smoking, proper training, a healthy diet, and avoidance of obesity, can help to reduce the risk of heart attack.

9.7 ELECTROCUTION

WARNING

Your Helmet is NOT designed to protect you against electrocution. When entering a building, you should NEVER touch live wiring, especially if your Helmet is wet. Never allow hoses, nozzles or other fire equipment you are operating to contact live wiring.

9.8 USING YOUR HELMET IN PROXIMITY FIREFIGHTING OPERATIONS

DANGER

For Proximity applications, make sure that the gold faceshield, aluminized cover and shroud components are fully engaged, leaving no skin exposed. Proximity firefighting application involving high levels of radiant heat are extremely dangerous environments and can cause burn injuries in a matter of seconds.

9.9 ADDITIONAL FACTORS AFFECTING SAFETY

The following additional factors may affect the limited protection provided by the Helmet:

- Conditions on the fire ground beyond the scope of the limited purposes of this Helmet;
- Unauthorized modifications, repairs or replacement of components of the Helmet not otherwise in compliance with LION's specifications; and
- The addition of accessories that are not approved by LION as compatible with NFPA 1971 Compliant Helmets should not be used. If you have questions about whether accessories will degrade the performance of your Helmet below the NFPA 1971 Standards, contact LION, LION TotalCare® or a verified ISP.

10. CLEANING, DECONTAMINATION AND DISINFECTION

10.1 HAZARDS

You can be exposed to many hazardous substances on the job. These substances can contaminate your Helmet, and cause harm to you after your body contacts your Helmet. This section tells you how to clean and decontaminate your Helmet to reduce these hazards.

Routine Fireground Contaminants: Many fire combustion products—including hydrocarbons, polynuclear aromatic compounds, metals such as cadmium and chromium, acids, and soot—are hazardous to the wearer of a protective Helmet. These substances can become embedded on the surface of the Helmet shell and in the headband and impact assembly, and enter the body through absorption, inhalation, parenteral contact and ingestion. In addition, particulates and other products of combustion can reduce the flame resistance of your Helmet and increase its ability to conduct electricity.

WARNING

To reduce the risk of long-term harm from hazardous substances present in the products of fire combustion or hazardous chemicals, you **MUST** clean your Helmet.

Hazardous Chemicals: If you experience accidental or incidental exposure to a hazardous chemical, follow all precautions in this section to limit exposure and risk of harm to yourself and others. You should hose down contaminated Helmets at the scene to limit further exposure to hazardous chemicals, to prevent exposure to others, and to prevent contaminants from settling into your Helmet.

Bloodborne Pathogens: Your Helmet may be exposed to body fluids that may contain bloodborne pathogens. The cleaning procedures described later in this section will reduce your risk of infection from these hazards.

10.2 **FREQUENCY**

Clean Helmets at least annually or as soon as possible after exposure to products of combustion, as well as contamination or exposure to tars, fuels, oils, resins, paints, acids, or any other hazardous substances.

10.3 **CLEANING PRODUCTS**

Routine Washings:



Do Not Bleach

- A. Commercially available detergents. Use commercially available detergents with a pH greater than 6.0 and less than 10.5. Many household detergents fall within this range.
- B. Specialty Cleaners. StationCare 1851 from LION TotalCare® is designed for NFPA 1971 Garments. Always read SDS sheets before use.
- C. Spot cleaning and pre-treating. Use commercially available detergents with a pH greater than 6.0 and less than 10.5. Always check SDS and product's instructions before use.



StationCare 1851 is available online at www.lionprotects.com/totalcare.

WARNING

NEVER use chlorine bleach or chlorinated detergents to clean your protective Helmet.

Even small amounts of chlorine will seriously reduce the protective qualities of your Helmet and ear/neck protector.

WARNING

Do not use petroleum-based solvents or paint thinners as they may degrade the protective properties of the Helmet components and cause burns or other serious injuries.

10.4 **CLEANING PROCEDURE**

If disassembly is needed to thoroughly clean the Helmet, refer to disassembly instruction in 7.3 prior to cleaning.

- A. **Shell:** Fill utility sink with warm water not exceeding a temperature of 105° F (40.6° C). Add cleaning product. Use a brush or sponge to wipe off contaminants, soot or dirt. Rinse with clean water. Wipe dry or air dry.
- B. **Components:** Fill utility sink with warm water and cleaning product. Wash browpad, ratchet pad and ear covers. Air dry completely at room temperature.
- C. **Faceshield/Goggles:** Fill utility sink with warm water with cleaning product. Clean faceshield with soft cloth and rinse with clean water. Dry with a soft sponge or cloth. Do not use abrasive solvents, or alcohol-based cleansers, as they may damage protective properties of the faceshield.

WARNING

Do not hang this Helmet in direct or indirect sunlight, or fluorescent light. Ultraviolet light (UV rays) will severely reduce the strength and protective qualities of the Helmet.

10.5 DECONTAMINATION AND DISINFECTION

Applicable Standard. You must read and have facilities and procedures in compliance with NFPA 1581 Standard for Fire Department Infection Control Program.

CAUTION

Personnel involved in the handling, sorting, bagging, and transporting, of contaminated Helmets must wear protective gloves and appropriate protective clothing to prevent occupational exposure during these activities. For more information, read OSHA rules at 29 CFR 1910.1030.

WARNING

To reduce risk of harm from hazardous substances present in products of fire combustion, hazardous chemicals, and body fluids, you **MUST** wash, decontaminate and/or disinfect your Helmet after each exposure to hazardous substances

Preparation. Remove contaminated/infected Helmet from wearer and service before beginning. Keep Helmet out of service until decontaminated and disinfected. Wear protective gloves and appropriate protective clothing and equipment while decontaminating and disinfecting.

If you have questions concerning the use of a particular disinfectant, contact LION, a LION TotalCare® Center, or verified ISP.

- A. **Hazardous Substances Present in the Products of Fire Combustion (Soot, Smoke and Debris):** To reduce the risks associated with exposure to the hazardous substances found in the products of fire combustion, you **MUST** wash, dry and store your Helmets according to the procedure in this section. Place Helmets in bags to limit exposure to others. Contact LION TotalCare or a Verified ISP to arrange for disinfection.
- B. **Hazardous Chemicals:**
1. Hose down contaminated Helmets at the scene to limit further exposure to hazardous chemicals, to limit exposure to others and to limit chemicals from settling into the Helmet.
 2. **KNOWN MATERIALS:** Contact the source of the materials, your local HAZMAT Team, your local HAZMAT team, or the Health Department to determine whether contaminants are hazardous materials. If the contaminant is known, contact a LION TotalCare® Center or verified ISP to determine feasibility of decontamination.
 3. **UNKNOWN MATERIALS:** If the contaminant is not known, Helmets should remain out of service until the materials are identified. Always demand SDS information and be prepared to share finding with the LION TotalCare® Center or verified ISP to decontaminate the Helmets. **If your Helmet cannot be decontaminated, it must be retired and disposed of in accordance with federal, state and local regulations.**
- C. **Blood and Body Fluids:** Place Helmets in bags to limit exposure to others. Contact LION TotalCare® or a Verified ISP to arrange for disinfection.

10.6

CLEANING AND DECONTAMINATION OF ALUMINIZED COMPONENTS

Radiant heat reflectivity of the aluminized surface is a key factor in heat protection during proximity firefighting operations. Keep the aluminized Helmet cover, aluminized Helmet shroud and gold-coated faceshield as clean as possible.

Cleaning: (Soft cloths prevent damage to aluminized or gold-coated surfaces)

Cover and Shroud: Gently wipe with a soft cloth wetted with cleaning product, then wipe again with clear warm water not exceeding a temperature of 105° F (40.6° C). Do not dry clean. Do not machine wash.

Gold-coated faceshield: Gently wipe with a soft cloth wetted with cleaning product, then wipe again with clear warm water not exceeding a temperature of 105° F (40.6° C).

Drying:

Cover, Shroud and Faceshield: Air dry in a cool shaded area away from sunlight or other sources of ultraviolet light. Do not tumble dry.

WARNING

DO NOT put Aluminized Components in washer or dryer. Mechanical action of the washer or dryer will compromise radiant heat protection provided by the reflectivity of the surface.

DANGER

Components should never be used unless thoroughly cleaned and dried. Fire by-products and residues built up on components can be flammable and cause the gear to fail to provide adequate protection. Failure to thoroughly clean and dry gear may cause serious injury or death.

11. REPAIR METHODS/INSTALLATION OF REPLACEMENT PARTS

WARNING

Before any repairs are made to Helmets, they must be cleaned in accordance with cleaning instructions. It is against OSHA guidelines to expect workers to alter or repair soiled and possibly contaminated Helmets.

With the exception of the Helmet shell, LION Helmets™ are designed to allow the user to remove and replace most components in the field. Contact your LION Helmet™ dealer to order replacement parts.

The diagrams on the following pages give nomenclature and placement of Helmet parts. Specific replacement/installation instructions are included in designated replacement parts and repair kits. Contact your nearest LION Helmet™ dealer or a LION TotalCare® Center for a list of available replacement parts and kits.

11.1 HELMET SHELLS

For damage to Helmet shells, other than cosmetic damage such as scratches or abrasions that are not repairable in the field, consult with LION TotalCare® for advice on feasibility of Helmet repair. Also read Section 13 for Retirement Considerations.

TRADITIONAL-STYLE HELMETS

- | | |
|--|---------------------|
| 1. Trim | 8a. Suspension Ring |
| 2. Ear Cover | 8b. Comfort Cap |
| 3. Chinstrap | 9. Eagle |
| 4. Faceshield (Metal Thumbwheels) | 10. D Ring |
| 5. Faceshield Bracket | 11. Welting |
| 6 & 7. Deluxe Leather Ratchet Headband | 12. Dowel Pins |
| 6a & 7a. Padded Ratchet Headband | |

American Heritage™ Helmet

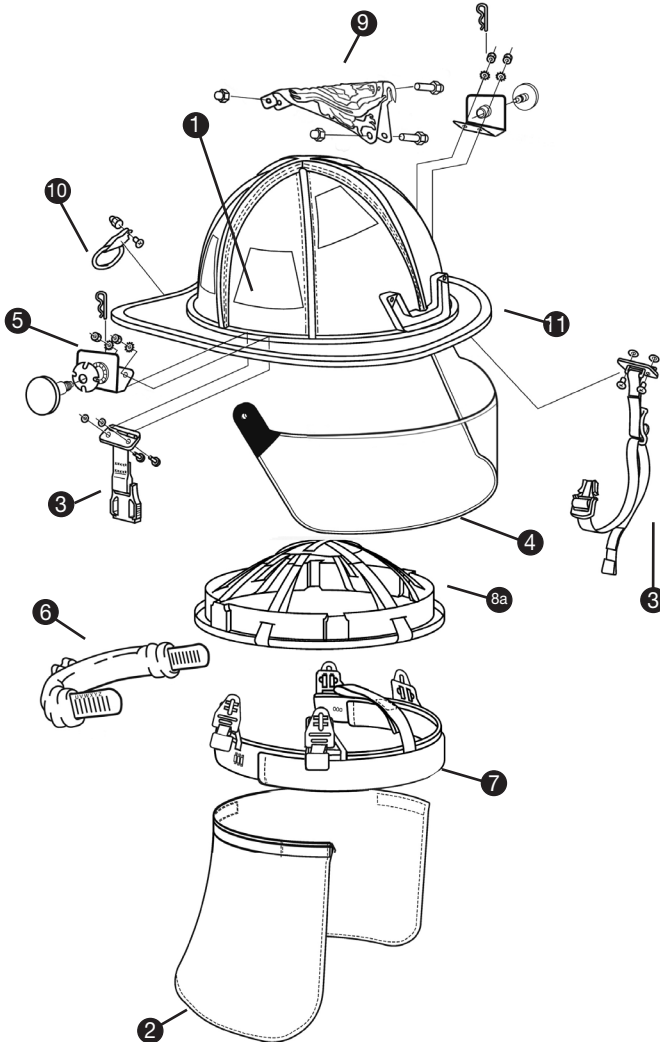

TRADITIONAL-STYLE HELMETS

- | | |
|--|---------------------|
| 1. Trim | 8a. Suspension Ring |
| 2. Ear Cover | 8b. Comfort Cap |
| 3. Chinstrap | 9. Eagle |
| 4. Faceshield (Metal Thumbwheels) | 10. D Ring |
| 5. Faceshield Bracket | 11. Welting |
| 6 & 7. Deluxe Leather Ratchet Headband | 12. Dowel Pins |
| 6a & 7a. Padded Ratchet Headband | |

American Classic™ Helmet

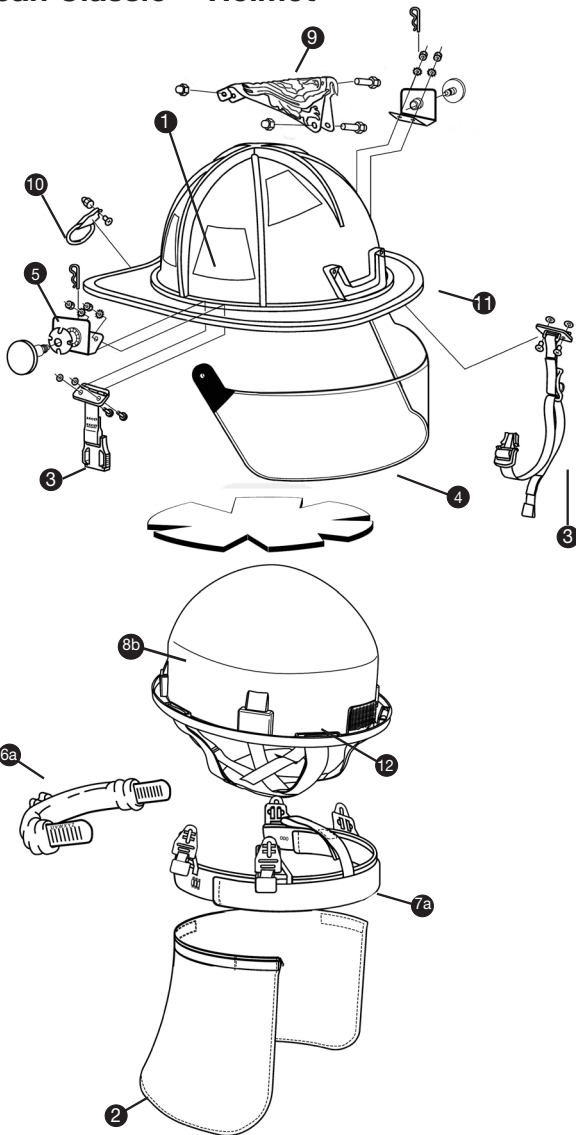

MODERN-STYLE HELMET

1. Trim
2. Ear Cover
3. Chinstrap
4. Faceshield
5. Faceshield Bracket
- 6 & 7. Headband
8. Impact Cap
9. Hanging Ring

Legacy™ Helmet

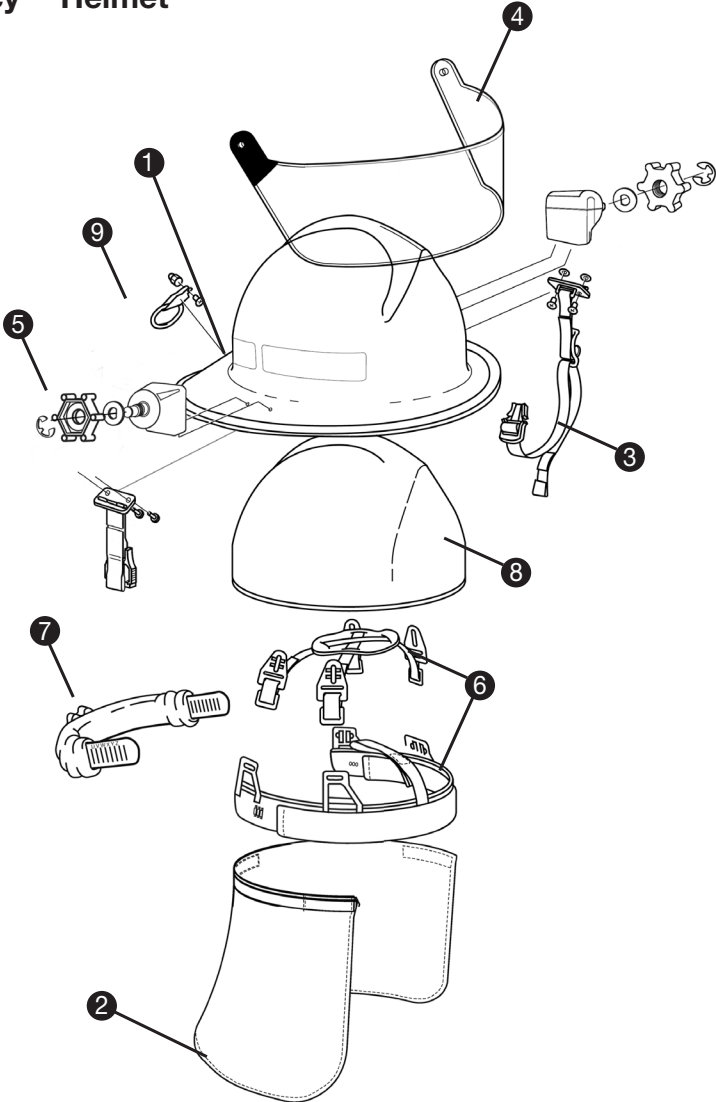

ALUMINIZED HELMET CONFIGURATION

- | | |
|-----------------------|----------------------|
| 1. Trim | 6 & 7. Headband |
| 2. Aluminized Shroud | 8. Impact Cap |
| 3. Chinstrap | 9. Hanging Ring |
| 4. Faceshield | 10. Aluminized Cover |
| 5. Faceshield Bracket | |

Legacy™ 5 Helmet

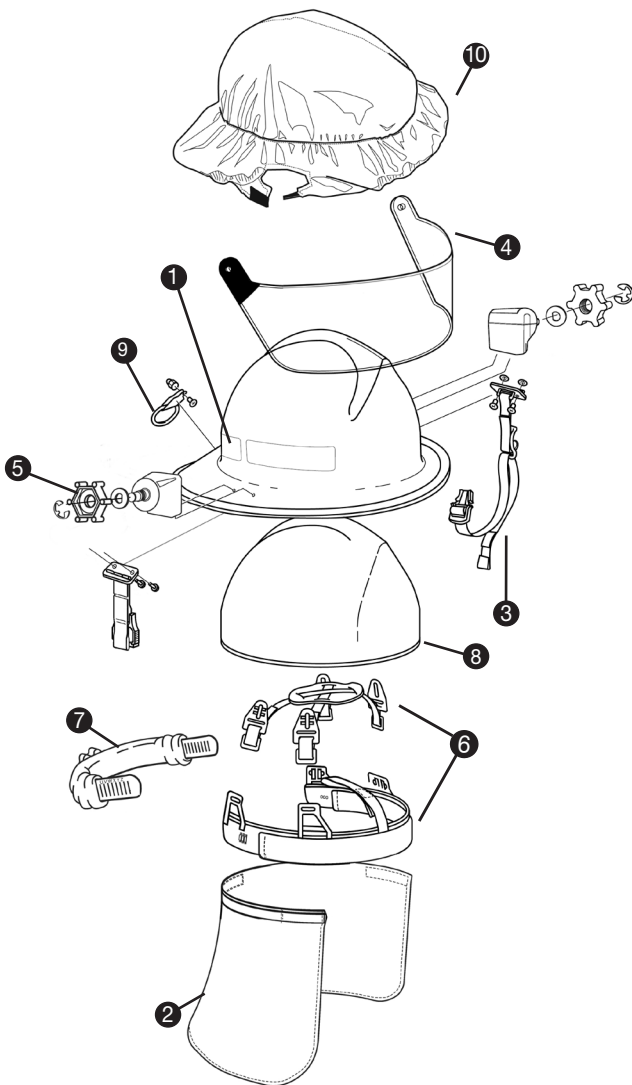

ALUMINIZED HELMET CONFIGURATION

- | | |
|-----------------------|----------------------|
| 1. Trim | 6 & 7. Headband |
| 2. Aluminized Shroud | 8. Impact Cap |
| 3. Chinstrap | 9. Hanging Ring |
| 4. Faceshield | 10. Aluminized Cover |
| 5. Faceshield Bracket | |

Aluminized American Classic™ Helmet

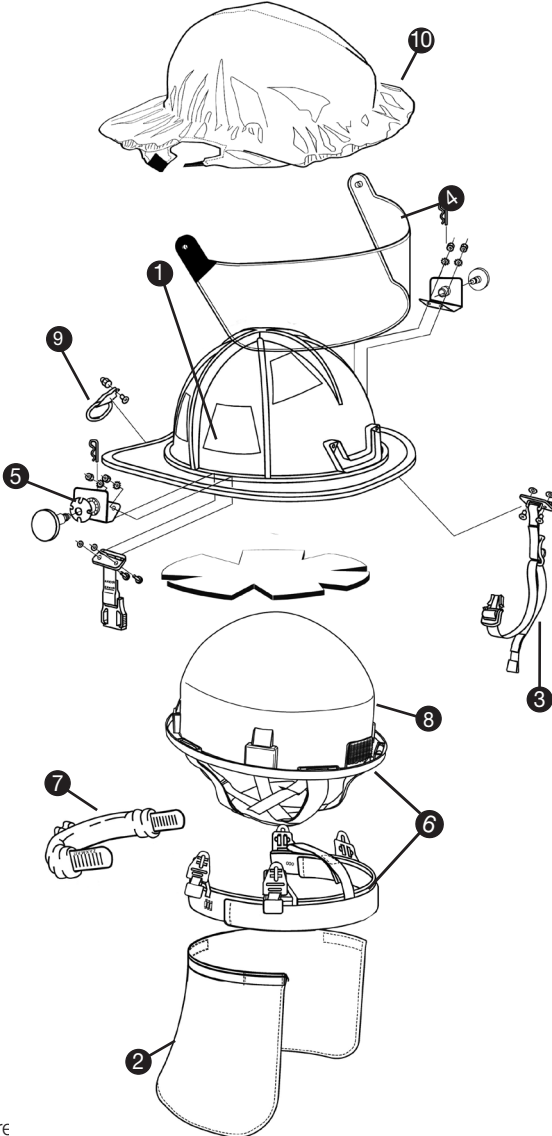

12. STORAGE

Between runs and for longer term storage, store your Helmet out of direct sunlight, indirect sunlight or fluorescent light. Use fans to provide good ventilation to dry Helmets which may have absorbed water or sweat after a run and/or to ensure the removal of any contaminants which may not have been removed by cleaning.

Avoid prolonged exposure of your Helmet to temperature extremes.

Failure to dry your Helmet will result in the growth of mildew and bacteria which could lead to skin irritation, rashes or may affect the protective qualities of the fabrics and moisture barrier materials.

Always clean and dry your Helmets in accordance with the Washing Section of this Guide and before long-term storage.



Never store your Helmets in direct sunlight, indirect sunlight or fluorescent light.

WARNING

NEVER STORE YOUR PROTECTIVE HELMET IN DIRECT SUNLIGHT, INDIRECT SUNLIGHT or FLUORESCENT LIGHT. Exposure to ultraviolet light (found in the sun's rays and fluorescent light) will severely weaken and damage some of the materials in your Helmet, especially the ear cover, after only A FEW DAYS. Damage from UV exposure can not be repaired, nor will the manufacturer cover such damage in its warranty. (See Warranty Information, Section 15.)

CAUTION

Do not store your Helmet with contaminants such as oils, solvents, acids or alkalis as these can damage the Helmet.

CAUTION

NEVER store your Helmet in living quarters with personal belongings, or within the passenger compartment of vehicles. Prolonged exposure to fireground contaminants that may have settled into a used or dirty Helmet may increase the risk of cancer or other diseases.

12.1 STORAGE OF PROXIMITY COMPONENTS

Store proximity components in a cool, dry location out of direct sunlight, indirect sunlight or fluorescent light and away from sharp objects that may cause tears or snags in the fabric and avoid storage and handling of components in a manner which will scratch the gold coating from the surface of the proximity faceshield, or abrading the aluminized coating from the Helmet cover and shroud.

13. RETIREMENT

13.1 USEFUL LIFE AND RETIREMENT

NFPA 1971 performance requirements are based on new, unworn Helmets and components. Useful life is the period of time that Helmets that have been properly cared for can be expected to provide reasonable limited protection. Useful life of Helmets or Helmet components can be as little as 3 to 5 years with heavy wear and tear and improper maintenance and/or storage. Useful life can be as long as 7 to 10 years if Helmets have been subject to relatively lower levels of wear and tear and have been consistently maintained in a regular cleaning and maintenance program and stored properly.

In compliance with NFPA 1851, Helmets must be retired no more than 10 years from the date of manufacture.

The useful life of a Helmet will vary according to the following factors:

- A. Age and frequency of use – Helmets used at the busiest stations will not last as long as at less busy stations.
- B. The length of exposure to extreme heat, extreme cold, and the intensity of the heat – Exposure to extreme heat and flame can cause damage to the Helmet shell, impact cap and other components.
- C. The length of exposure to hazardous materials – If the exposure to hazardous materials is severe, and cleaning is ineffective, the Helmet may not be safe for further use.
- D. The length of exposure to sunlight, or other light containing UV rays – Long term exposure to UV light causes components to become brittle or weak.

Your Helmets should be assessed by trained professionals at each regular Advanced Inspection to determine whether it has exceeded its useful life and must be retired. Your Helmet must be removed from service when it can no longer be safely used, and when the cost of repair would exceed 50% of the cost of replacement.

The details of a retirement program should be handled by trained professionals with in depth knowledge of firefighter Helmets and their limitations. **If you have any questions about the continued functionality of your protective Helmet, get assistance before wearing it into any emergency situation! Contact a trained expert within your department, LION, a LION TotalCare® Center or a verified ISP.**

WARNING

For Proximity Helmets, heavily abraded aluminized coatings and gold faceshields with a large number of scratches will not reflect radiant heat and should be retired. Use of damaged proximity components may result in serious burns to the face or head area.

14. DISPOSAL

Retired protective Helmets should be destroyed to prevent their unauthorized or mistaken use. Separate the Helmet into several pieces and dispose of properly. One suggested method of disposal is a landfill.

Retired Helmets which are contaminated with hazardous chemicals should be placed in a plastic bag and properly disposed. You should follow local and state regulations governing disposal of contaminated materials.

WARNING

Never use retired Helmets for training purposes. Use of retired Helmets may result in serious injury or death.

15. LIMITED LIFETIME PRODUCT WARRANTY

LION warrants that its firefighter and emergency responder products meet all applicable NFPA standards in effect at the time of their manufacture and further warrants that such products are free during their useful life from any defect in workmanship or any material defect.

LION will replace any LION Classic Helmet or LION Legacy Helmet shell damaged during normal fire department firefighting activities, for a period up to five (5) years after date of Helmet manufacture, for Helmets manufactured by LION.

Conditions of use are outside the control of LION. It is the responsibility of the user to inspect and maintain the products to assure they remain fit for its intended purpose. In order to maximize the useful life of these products and maintain the warranty, the products are to be used only by appropriately trained personnel following proper firefighting or emergency response techniques and in accordance with the product's warning, inspection, maintenance, care storage and retirement instructions. Failure to do so will void the warranty.

EXCEPT AS SET FORTH ABOVE, LION MAKES NO OTHER WARRANTIES, EXPRESS OR IMPLIED, INCLUDING BUT NOT LIMITED TO, ANY WARRANTIES OF MERCHANTABILITY OR FITNESS FOR ANY PARTICULAR USE.

Under the above warranties, LION will repair or replace, at its option, any protective product which does not meet the above warranties. Such repair or replacement will be purchaser's sole remedy, and LION will not be responsible for any incidental, consequential or other damages based upon or arising in any way from any breach of the warranties contained herein, or purchaser's use of such product.

These warranty obligations apply only to any product, part, or component which is returned to LION or a LION TotalCare® Center with prior authorization and proof of purchase, and which LION agrees to be defective as covered by this warranty.

The word "product" includes the product itself and any parts or labor furnished by LION with the sales, delivery or servicing of the product.

USEFUL LIFE: NFPA 1971 performance requirements are based on new, unworn Helmets. Useful life is the period of time that

an NFPA 1971 compliant Helmet, which has been properly cared for, can be expected to provide reasonable limited protection.

Useful life of Helmets or Helmet components can be as little as 3 to 5 years with heavy wear and tear and improper maintenance and/or storage. Useful life can be as long as 7 to 10 years if Helmets have been subject to relatively lower levels of wear and tear and have been consistently maintained in a regular cleaning and maintenance program and stored properly. In compliance with NFPA 1851, Helmets must be retired no more than 10 years from the date of manufacture.

DEFECTS IN WORKMANSHIP AND MATERIALS:

Poorly manufactured items, including seams, stitching, or components (for example, loose or broken assembly components, straps or other pieces that fall off or do not function properly; chipped or cracked shells, or broken impact caps.)

15.1 EXCEPTIONS TO LIMITED WARRANTY

This limited warranty does not cover the following items after receipt of products by end user:

- A. Claims made after 60 days from the date of shipment for damage caused by shipment;
- B. Damage or color change from exposure of materials to direct or indirect sunlight or fluorescent light;
- C. Shade variations among textiles used, or shade changes caused by wear-and-tear or washing;
- D. Color loss due to abrasion ;
- E. Damage caused by improper washing, decontamination, disinfection or maintenance (for example, use of chlorine or petrochemicals to clean);
- F. Damage caused by repair work not performed to factory specification;
- G. Damage from routine exposure to common hazards which may cause rips, tears, burn damage, or abrasion;
- H. Loss of retroreflectivity of reflective trim due to normal wear or heat exposure;
- I. Detachment of reflective trim due to heat exposure or adhesive failure;
- J. Replacement of fasteners damaged by normal wear and tear;
- K. Loss of hardware caused by normal wear and tear.

NOTES:

Earn your LION
NFA 1500 PPE Safety
and Use Certificate



PERSONAL RESPONSIBILITY CODE



The member companies of FEMSA that provide emergency response equipment and services want responders to know and understand the following:

1. Firefighting and Emergency Response are inherently dangerous activities requiring proper training in their hazards and the use of extreme caution at all times.
2. It is your responsibility to read and understand any user's instructions, including purpose and limitations, provided with any piece of equipment you may be called on to use.
3. It is your responsibility to know that you have been properly trained in Firefighting and/or Emergency Response and in the use, precautions and care of any equipment you may be called upon to use.
4. It is your responsibility to be in proper physical condition and to maintain the personal skill level required to operate any equipment you may be called upon to use.
5. It is your responsibility to know that your equipment is in operable condition and has been maintained in accordance with the manufacturer's instructions.
6. Failure to follow these guidelines may result in death, burns, injury, diseases, and illnesses.



© 2018 FEMSA, All Rights Reserved, Fire and Emergency Manufacturers and Services Association, Inc.

www.femsa.org

Entire Contents © 2024

July 2024



©2024 LION GROUP, INC. ALL RIGHTS RESERVED. THIS GUIDE IS PROTECTED UNDER THE COPYRIGHT LAWS OF UNITED STATES AND THE INTERNATIONAL COPYRIGHT CONVENTION. NO PART OF THIS GUIDE MAY BE REPRODUCED WITHOUT THE EXPRESSED WRITTEN CONSENT OF LION.